



TECHNICAL SPECIFICATIONS



Compaction Roller Range	MBR-71	TV800	TV900	TV1000	TV1200
Operating Weight kg (lbs)	513 (1130)	1559 (3437)	1568 (3457)	2570 (5665.8)	2925 (6448.5)
Static Linear Load kg/cm (lb/in)	7.2 (40.3)	9.7 (54.3)	8.7 (48.7)	12.85 (71.9)	12.18 (68.2)
Frequency VPM	3900	2760 / 3120	2760 / 3120	2880 / 3360	2880 / 3360

→ TECHNICAL DATA PEDESTRIAN ROLLER MBR71

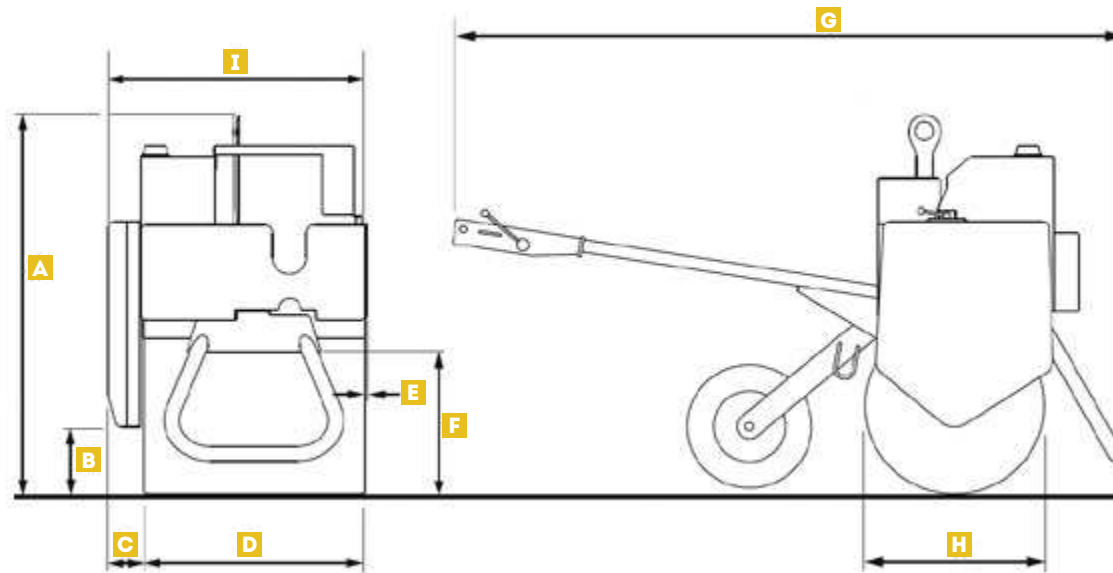

DIMENSIONS mm (ft in)	DATA
A Overall Height	1225 (4')
B Curb Clearance - Farside	468 (1'6")
C Overhang - Farside	38 (1.5")
D Drum Width	710 (2'4")
E Overhang - Curbside	25 (1")
F Curb Clearance - Curbside	380 (1'3")
G Overall Length	2187 (7'2")
H Drum Diameter	Ø575 (1'11")
I Machine Width	772 (2'6")
Drum Shell Thickness (not shown)	8

PERFORMANCE	DATA
Total Static Basic Weight kg (lbs)	496 (1093)
Operating Weight kg (lbs) CECE	511 (1126)
Static Linear Load kg/cm (lb/inch)	7.2 (40.3)
Frequency - Hz (VPM)	65 (3900)
Amplitude (mm)	0.57
Centrifugal Force kN (lbf)	15 (3372)
Gradeability - without Vibration	33%
Gradeability - with Vibration	25%

ENGINE & DRIVE	
Engine Make	Hatz
Engine Model	1B50T
Cylinders	1
Displacement cc (in ³)	517 (31.5)
Cooling	Air
Power - kW (HP) (DIN ISO 1585)	7.3 (9.8)
Operating Speed (rpm)	3000
Fuel Type	Diesel
Drive	Hydrostatic
Maximum Travel Speed (kph) - Forwards	4 (2.5)
Maximum Travel Speed (kph) - Reverse	2 (1.2)
Braking System - Service	Dynamic Hydrostatic
Braking System - Parking	Spring apply hydraulic release
Start Type	Electric

CAPACITIES	
Hydraulic Tank Capacity ltr (gallons (US))	12.5 (3.3)
Fuel Tank Capacity ltr (gallons (US))	5 (1.32)
Water Tank Capacity ltr (gallons (US))	27 (7.13)

EMISSIONS	
Noise (dB) - LwA (2000/14/EC / ISO 4871)	92dB
Engine Emissions	EU Stage V / U.S. EPA Tier 4 Final*
Hand Arm Vibration (HAV) - (EN500-4)	3.6m/s ²

EXCITER	
Type	Single Shaft
Drive	Hydraulic Motor

WATER SPRAY SYSTEM	
System Type	Gravity Fed with Non-Corrosive Spray Bar

DRUM SCRAPER BARS	
System Type	Heavy Duty Adjustable - Front and Rear

STANDARD EQUIPMENT

Gravity Fed Water System
Drum Scraper Bars Front and Rear
Low Maintenance Battery (12V)
Emergency Release Free Wheel Valve
Heavy Duty Central Lifting Point
Battery Isolator
Emergency Stop
Front Prop Stand
Rear Jockey Wheel
Electric Starting
Hour Meter
30L/min Hydraulic Take-off Valve

OPTIONAL EQUIPMENT

Stanley BR50 Vibro-Damped Hydraulic Breaker with Tools, Valve and Hosing (light use only)
Stanley BR67 Vibro-Damped Hydraulic Breaker with Tools, Valve and Hosing (must be carried on towing vehicle)
'Towit' Tow-Behind Trailer with Storage Box, Prop-Stand, Number Plate Lighting and Road Lighting
'Towit' Tow-Behind Trailer, Longer Break-away Tether Cable with Clip on Hook

**Standard and optional equipment may vary.
Consult your Mecalac dealer for details.**

*Depending on your Local Legislation - Environmental Protection Agency (EPA)

NOTE

METRIC MEASUREMENTS ARE THE CRITICAL VALUES

- 1 Litre = 0.26417 US Liquid Gallons
- 1 Litre = 0.21997 Imperial Liquid Gallons